



δ^t delta T
Technical Data Manual

CONTENTS

Design for High Performance	p1
Design for Efficient Thermal Performance	p2
Benefits of delta T	p4
Sensors and Microprocessor Display	p6
Unit Components	p8
RowBOT	p9
Performance Data	p10
Unit Technical Specification	p15
Statutory Information	p18

DESIGN FOR HIGH PERFORMANCE

High performance low cost computing has transformed the way organizations work. Datacenters are fundamental to that transformation, and their performance is playing an increasingly critical role in organizational effectiveness.

The Datacentience delta T* is a close coupled cooling unit, created to help organizations realize the potential of next generation high density datacenter design. Blade servers offer vastly increased computing power within a smaller physical footprint than ever before, bringing valuable economies of scale. But this high density (HD) datacenter design makes demands on cooling concepts which highlight the inadequacy of traditional thinking. The delta T unit has been designed from the ground up to meet the escalating needs of business for reduced power consumption, and more effective and reliable cooling.

Above all the delta T supports truly scalable installations that can expand (or indeed contract) in line with shifts in organizational requirements, all with minimum disruption to datacenter operation.

* Patent pending

DESIGN FOR EFFICIENT THERMAL PERFORMANCE

Conventional designs use multiple downflow computer room air conditioning (CRAC) units to blow cold air onto the server racks. This is fundamentally inefficient, not least because cooled air in the room returning to the CRAC units reduces their cooling effectiveness. Equally a conventional approach to “redundancy” (where a single backup unit is installed to compensate for individual CRAC unit failure) ignores the reality of airflow around a room and the influence of that airflow on temperatures at the server intakes. True redundancy (and therefore datacenter reliability) using this approach would require a backup unit for every primary unit.

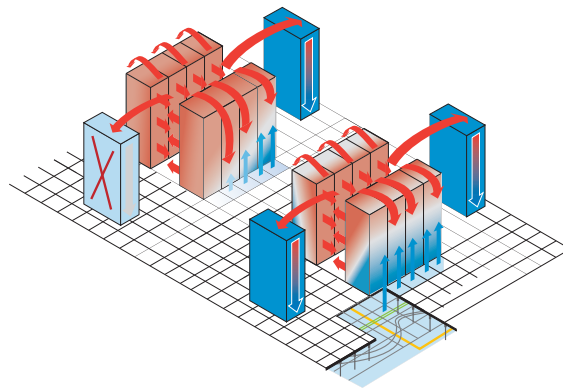

Fig.1 Even in well laid out rooms with a CRAC at the end of each hot aisle, a single unit failure results in unpredictable hot spots in front of the IT servers.

Rack layouts that create enclosed hot or cold aisles have become widely recognized as a better approach to HD datacenter design than conventional open rows. Cold aisle enclosure is an effective first step in addressing increased row density. But a cold aisle cooling solution that works by blowing cold air up through a raised floor space remains energy intensive and fundamentally inflexible.

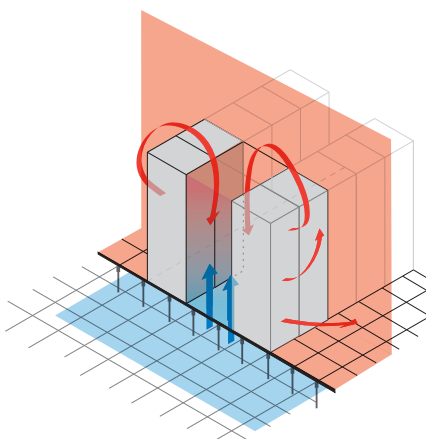

Fig.2 Conventional air supply from raised floor is inadequate to stop recirculation of hot aisle air.

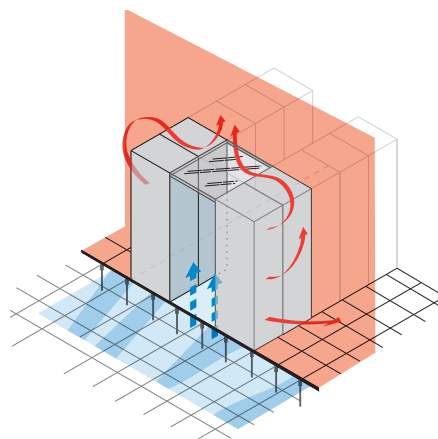

Fig.3 Cold aisle enclosure stops recirculation but relies on sufficient air supply from the raised floor. Obstructions in the floor void prevent sufficient delivery of cooled air.

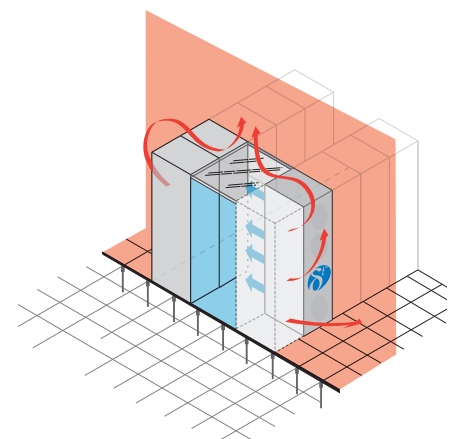

Fig.4 The delta T unit supplies conditioned air above the floor directly into the cold aisle. It does not impact on air distribution in the rest of the room and does not require a raised floor.

Rack mounted cooling is a more promising approach. Used in conjunction with enclosed cold aisles it overcomes the limitations of the traditional raised floor air distribution method. When used with enclosed hot aisles it works by removing hot air at source, rather than blowing cold air into the server space.

The delta T is a rack mounted cooling unit suitable for hot and cold aisle designs. It captures the hot air exhaust from the rear of the servers, and cools it to room temperature, using chilled water coils. Heat never enters the IT space, so the air temperatures at the server intake can be maintained reliably and constantly at the manufacturer's recommendation.

Capturing warm air from a hot aisle enclosure is particularly efficient, doubling the capacity of the cooling coils in comparison to enclosed cold aisle or open room solutions. In addition, it improves chiller performance, reducing the power draw by the chiller compressor in summer and offering longer periods of free cooling in winter. The delta T coil also cools the air without removing moisture, reducing or eliminating the need for costly humidifier operation to offer further energy savings.

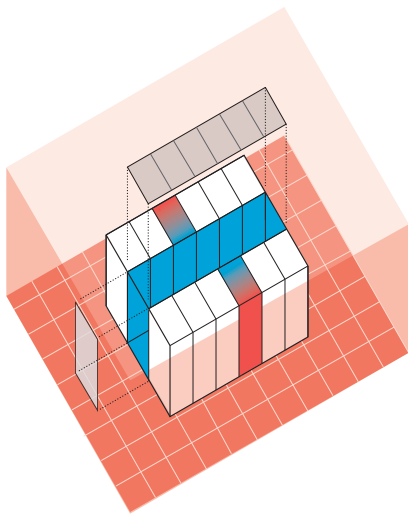

Fig.5 Enclosed cold aisle eliminates uncertainty of raised floor air distribution.

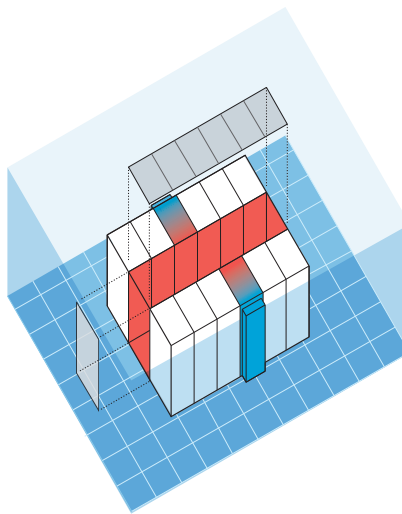

Fig.6 Hot aisle enclosure maximizes coil capacity, assures redundancy and can reduce chiller power.

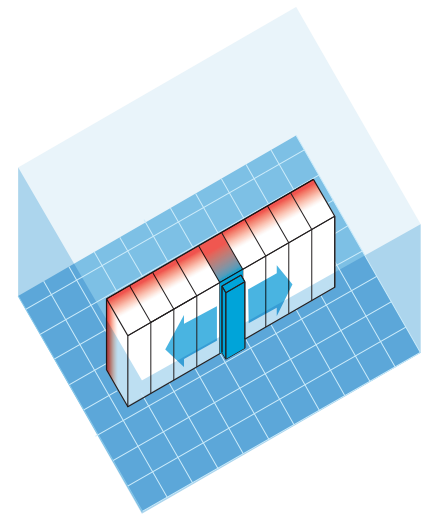

Fig.7 Semi recessed operation in open (or enclosed cold) aisles reduces fan power draw and provides an air curtain across the front of the IT servers. See p5 for further details.

Hot aisle enclosure offers more predictable thermal management and therefore greater system reliability. It can offer greater cooling capacity with lower energy consumption, shrinking the carbon footprint of the datacenter while enhancing overall performance.

BENEFITS OF delta T

The delta T cooling unit has been designed from the ground up to meet the real business demands of 21st century datacenters.

It is truly scalable. It can slide into any rack* much like an IT server, with minimum disruption to the datacenter room. Escalating demands on server capacity mean it is not always easy or practical to pre-plan rack cooling requirements. With the delta T such pre-planning is unnecessary. The unit can be easily retro-fitted to any rack to increase cooling capacity, exactly where it is needed and without disrupting either raised floor services or rack-top cabling. Quick fit connectors and flexible piping ensure easy fitting to mains water feeds.

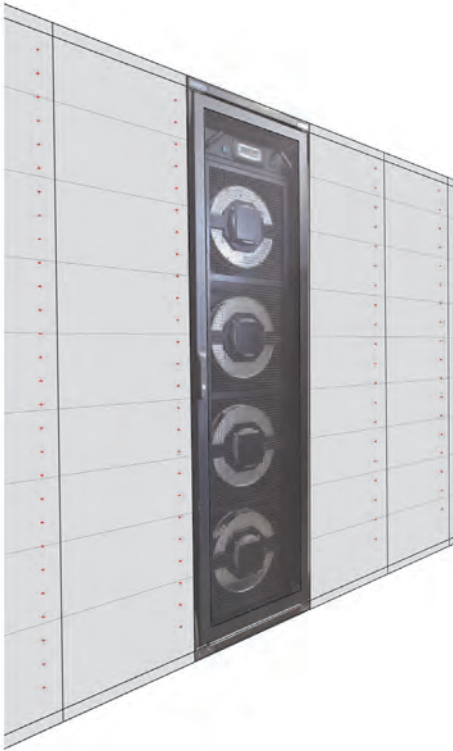

Fig.8

Fig.8 Fully recessed operation provides predictable cooling performance with 40 kW of cooling while using only 1360 Watts of power.

Fig.9 Semi recessed operation can provide 40 kW of cooling with only 930 Watts of fan power.

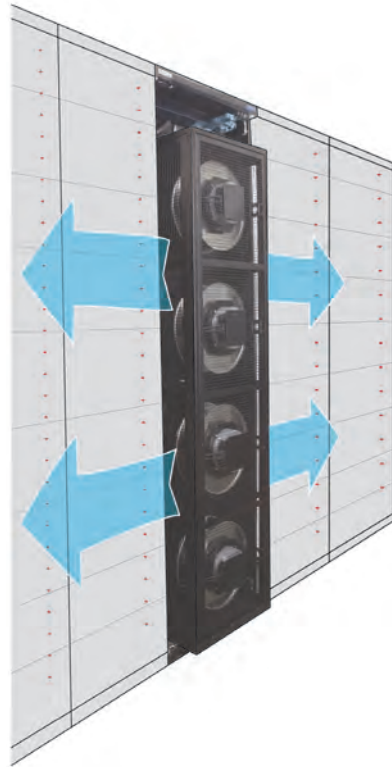

Fig.9

Where there is space you can even add a single rack or pair of racks to create a high density zone with no thermal impact on the rest of the room and no modification to any existing raised floor cooling.

For all installations the delta T offers optimized cooling performance with superior energy consumption characteristics. The unit uses electronically commutated DC fan motors to reduce energy drain, while a lower unit water side pressure drop minimizes the load on the chilled water pump. These factors can improve energy consumption up to 50% for the same cooling performance as downflow CRAC units using conventional raised floor air distribution.

* Slide into rack feature is subject to a pending patent

Placing the units in a semi-recessed position* further improves the energy efficiency of the fans.

delta T25

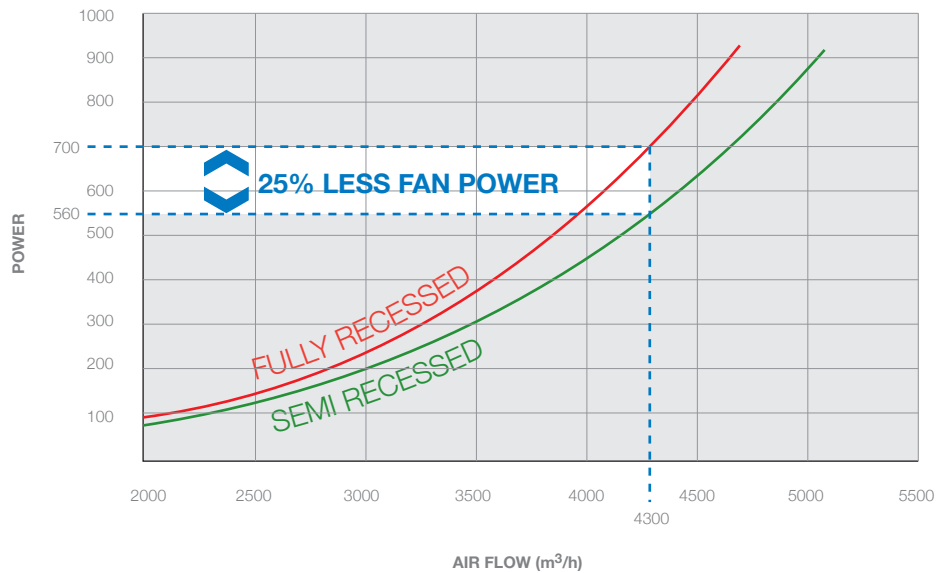

delta T50

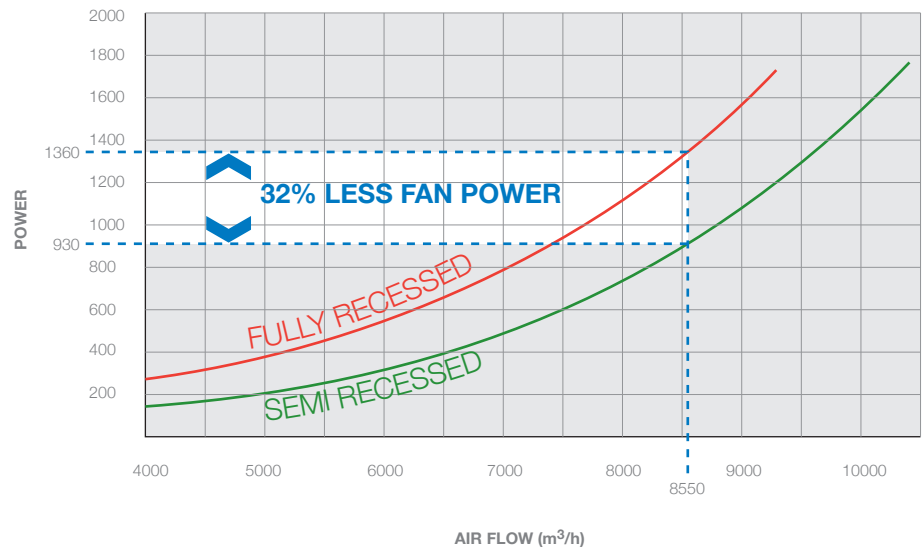

The system also offers lower overall capital costs. The ability to match cooling performance precisely to cooling load means you can make full use of your racks (concerns about overheating often lead to the upper slots of a rack being unused).

Because you can scale cooling capacity to meet real demands, you do not need to overspecify equipment in the initial design of the datacenter. The fundamental efficiency of this design approach (with cooling units located where they will have a predictable effect) also means you can achieve true failsafe redundancy with fewer cooling units.

* Semi recessed feature is subject to a pending patent

SENSORS AND MICROPROCESSOR DISPLAY



Fig.10 Easy to use microprocessor displays all operating parameters, modes and alarms.

A remote NTC temperature sensor placed inside the front door of an adjacent IT rack controls the variable fan speed. A second sensor located in the unit controls the modulating chilled water valve to maintain constant supply air temperature into the cold aisle. A third sensor sits in the unit's return air stream to monitor hot aisle temperature. A fourth sensor monitors entering chilled water temperature.

The microprocessor displays set points, alarms and operating mode. It can link up to eight cooling units in each zone. The four line backlit display shows:

Monitoring

- Room air temperature (intake to IT servers)
- Supply air temperature
- Entering water temperature
- Operating parameters
- Real time kW
- Real time air volume

Alarms

- Fan failure
- Loss of air flow
- Filter clogged
- Alarm history

The control keyboard is protected by two levels of password access.

RS485 (for BMS connection) and SNMP Web Card interfaces are available as standard options.

Microprocessor control and electrical panel

Individual unit operation and control is via a fully featured industry standard microprocessor. Operation and maintenance requirements will be familiar to most installation engineers. Optionally, the electrical panel can house two microprocessors for delta T 25 units in tandem operation and sharing a single display.

The electrical panel is housed in a separate 2U high drawer that can be located in the same rack as the unit or in an adjacent IT rack. The monitoring and control display at the front of the drawer can be remotely mounted.

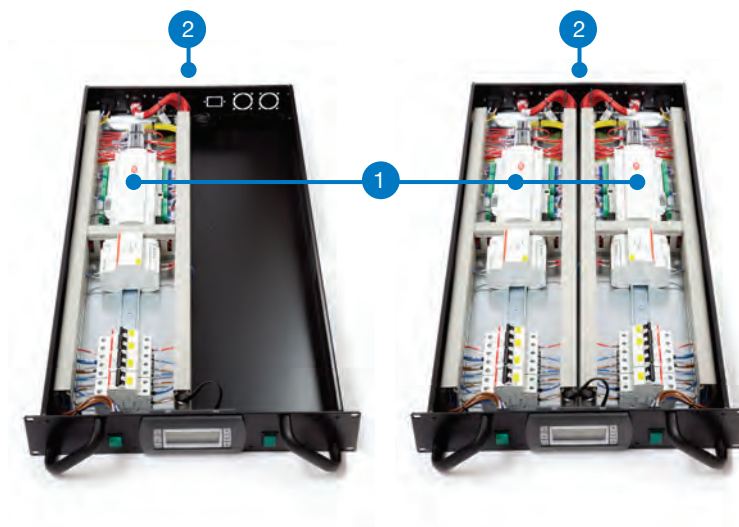

Fig.11 Electrical panel shown with both one and two microprocessors in tandem

- 1 Standard microprocessor
- 2 Remote temperature sensor

UNIT COMPONENTS

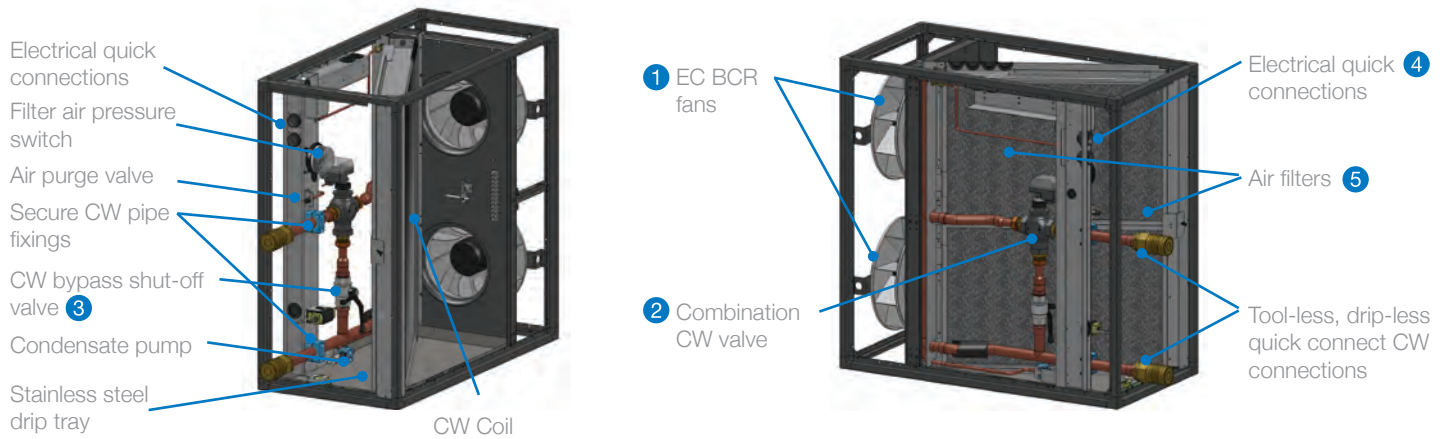

Fig.12

- 1 EC BCR electronically commutated fans, with a 75,000 hour L_{10} life. The fans use backward curved radial (BCR) blades, statically and dynamically balanced, giving exceptionally quiet running and high operating efficiency. There is a protective enclosure on the fan discharge.
- 2 Chilled water valve (2 or 3 way) located in return air stream complete with modulating electric actuator
- 3 Bypass (3 way only)
- 4 Electrical quick connections
- 5 Cleanable air filters (G2 with aluminum frame)

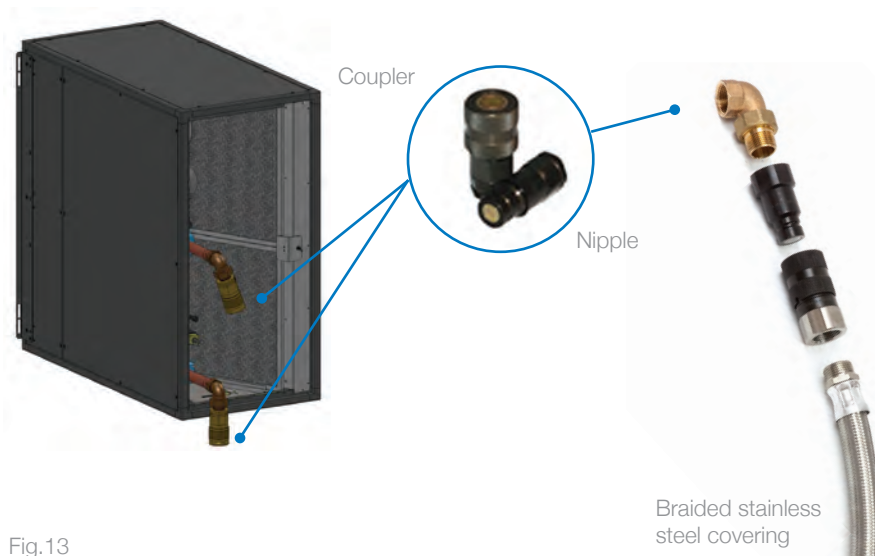

Fig.13

Optional

Tool-less drip-less quick connect couplings:

- Zinc plated steel couplings
- Hardened steel nipple for anti-brinelling
- Swaged seal to prevent extrusion
- No air inclusion during connection
- Flat mating surface easily cleaned

Flexible EPDM rubber pipes:

- Low pressure drop enhances efficiency in the entire system

RowBOT

The Row Build Out Tool (RowBOT) is a sophisticated modeling program, which reflects our deep rethinking of how cooling could be better implemented in HD datacenters. It brings a step change in the time required to design a rack and row-level cooling solution, whether for a new datacenter or within an existing installation.

If you're creating an HD data facility then you must consider hot or cold aisle enclosure: with the RowBOT you can model the features of both approaches and compare their relative benefits. Once you have settled on the optimal row layout for the room, you can link the RowBOT easily to popular third party design software packages and import the row configuration in a complete room design. For further insight you could then run a CFD analysis to simulate the performance of the high density rows and the entire room.

The RowBOT takes the guesswork out of designing an effective cooling solution.

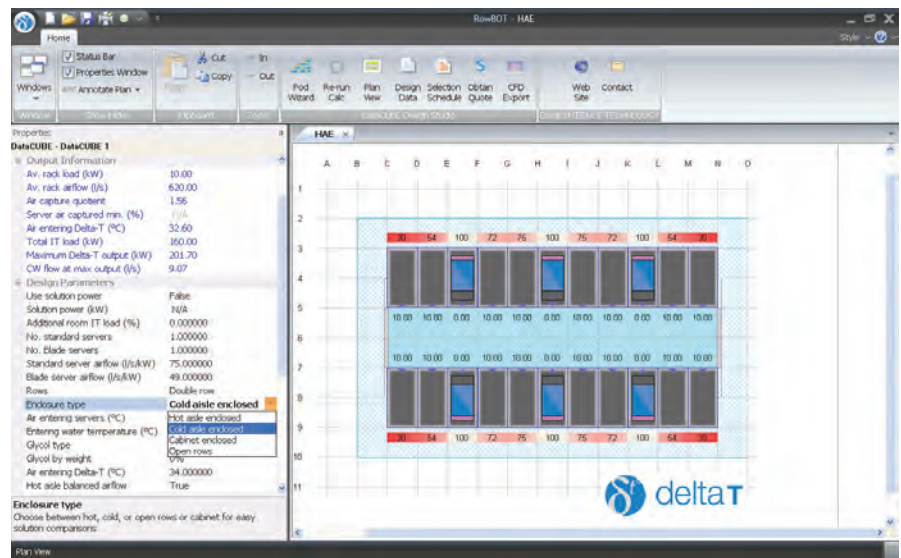

Fig.14 Row layout for predictable cooling designs is assured using the Datacentience RowBOT

PERFORMANCE DATA

Entering Water Temperature: 7.2°C (45°F)

Return Air Temperature		CW Temp Rise		delta T	Leaving Water Temp		Net Total Capacity		Net Sensible Capacity		SHR	CW Flow		CW Pressure Drop Coil + Valve			
°C DB	°F DB	°C	°F	Model	°C	°F	kW	MBH	kW	MBH	%	m³/h	GPM	kPa	Ft H ₂ O		
32	90	5.5	10	delta T 25	12.7	55	20.3	69.3	19.2	65.5	95	3.27	14.4	36	12.0		
				delta T 50			39.8	135.7	37.5	128.0	95	6.41	28.2	58	19.4		
		6.6	12	delta T 25	13.8	57	19.4	66.2	18.5	63.2	96	2.61	11.5	23	7.7		
				delta T 50			38.0	129.6	36.2	123.5	95	5.11	22.5	37	12.4		
		7.7	14	delta T 25	14.9	59	18.4	63.0	17.8	60.8	97	2.13	9.4	15	5.0		
				delta T 50			36.3	124.0	35.0	119.4	96	4.19	18.5	25	8.4		
		8.8	16	delta T 25	16.0	61	17.4	59.4	17.1	58.4	98	1.76	7.8	10	3.3		
				delta T 50			34.5	117.8	33.7	114.9	98	3.49	15.4	17	5.7		
		10.0	18	delta T 25	17.2	63	16.3	55.7	16.2	55.4	99	1.46	6.4	7	2.3		
				delta T 50			32.7	111.5	32.2	110.0	99	2.91	12.8	12	4.0		
		11.1	20	delta T 25	18.3	65	15.3	52.2	15.3	52.2	100	1.23	5.4	5	1.7		
				delta T 50			31.0	105.8	30.8	105.0	99	2.49	11.0	9	3.0		
		34	93	5.5	10	delta T 25	12.7	55	22.1	75.3	21.0	71.6	95	3.55	15.6	42	14.0
						delta T 50			43.2	147.4	41.0	140.1	95	6.94	30.6	68	22.7
6.6	12			delta T 25	13.8	57	21.2	72.3	20.3	69.4	96	2.84	12.5	27	9.0		
				delta T 50			41.4	141.3	39.7	135.5	96	5.55	24.4	43	14.4		
7.7	14			delta T 25	14.9	59	20.3	69.1	19.7	67.1	97	2.33	10.3	18	6.0		
				delta T 50			39.8	135.7	38.5	131.4	97	4.58	20.2	29	9.7		
8.8	16			delta T 25	16.0	61	19.3	65.8	19.0	64.8	99	1.94	8.6	13	4.3		
				delta T 50			38.0	129.8	37.2	127.1	98	3.83	16.9	21	7.0		
10.0	18			delta T 25	17.2	63	18.2	62.2	18.1	61.9	99	1.62	7.1	9	3.0		
				delta T 50			36.3	123.7	35.9	122.4	99	3.22	14.2	15	5.0		
11.1	20			delta T 25	18.3	65	17.3	59.0	17.3	59.0	100	1.39	6.1	6	2.0		
				delta T 50			34.7	118.3	34.4	117.5	99	2.78	12.2	11	3.7		
37	99			5.5	10	delta T 25	12.7	55	24.7	84.1	23.7	80.7	96	3.95	17.4	52	17.4
						delta T 50			-	-	-	-	-	-	-	-	-
		6.6	12	delta T 25	13.8	57	23.8	81.2	23.0	78.6	97	3.18	14.0	34	11.4		
				delta T 50			46.5	158.6	44.9	153.3	97	6.21	27.4	54	18.1		
		7.7	14	delta T 25	14.9	59	22.9	78.2	22.4	76.4	98	2.63	11.6	23	7.7		
				delta T 50			44.8	153.0	43.7	149.2	98	5.14	22.6	37	12.4		
		8.8	16	delta T 25	16.0	61	21.9	74.8	21.7	73.9	99	2.20	9.7	16	5.4		
				delta T 50			43.2	147.4	42.5	145.0	98	4.34	19.1	26	8.7		
		10.0	18	delta T 25	17.2	63	21.0	71.7	20.9	71.4	100	1.86	8.2	12	4.0		
				delta T 50			41.4	141.4	41.1	140.2	99	3.67	16.1	19	6.4		
		11.1	20	delta T 25	18.3	65	20.1	68.7	20.1	68.7	100	1.61	7.1	9	3.0		
				delta T 50			40.0	136.5	39.9	136.3	100	3.19	14.1	14	4.7		
		43	109	5.5	10	delta T 25	12.7	55	29.8	101.8	29.0	98.9	97	4.76	21.0	76	25.4
						delta T 50			-	-	-	-	-	-	-	-	-
6.6	12			delta T 25	13.8	57	28.9	98.5	28.3	96.4	98	3.84	16.9	49	16.4		
				delta T 50			56.4	192.6	55.2	188.3	98	7.51	33.1	79	26.4		
7.7	14			delta T 25	14.9	59	28.1	95.7	27.7	94.4	99	3.20	14.1	34	11.4		
				delta T 50			54.8	186.9	54.0	184.2	99	6.25	27.5	55	18.4		
8.8	16			delta T 25	16.0	61	27.2	92.7	27.0	92.0	99	2.71	11.9	25	8.4		
				delta T 50			53.2	181.6	52.7	180.0	99	5.32	23.4	40	13.4		
10.0	18			delta T 25	17.2	63	26.3	89.9	26.3	89.7	100	2.32	10.2	18	6.0		
				delta T 50			51.6	176.1	51.4	175.3	100	4.54	20.0	29	9.7		
11.1	20			delta T 25	18.3	65	25.6	87.2	25.6	87.2	100	2.03	8.9	14	4.7		
				delta T 50			50.3	171.7	50.2	171.3	100	3.99	17.6	22	7.4		

NB: CW Pressure Drop must be ≥ 5 kPa

PERFORMANCE DATA

Entering Water Temperature: 10°C (50°F)

Return Air Temperature		CW Temp Rise		delta T	Leaving Water Temp		Net Total Capacity		Net Sensible Capacity		SHR	CW Flow		CW Pressure Drop Coil + Valve			
°C DB	°F DB	°C	°F	Model	°C	°F	kW	MBH	kW	MBH	%	m³/h	GPM	kPa	Ft H ₂ O		
32	90	5.5	10	delta T 25	15.5	60	16.7	56.9	16.7	56.9	100	2.70	11.9	25	8.4		
				delta T 50			32.6	111.1	32.6	111.1	100	5.28	23.2	39	13.0		
		6.6	12	delta T 25	16.6	62	16.0	54.6	16.0	54.6	100	2.16	9.5	16	5.4		
				delta T 50			31.3	106.9	31.3	106.9	100	4.24	18.7	25	8.4		
		7.7	14	delta T 25	17.7	64	15.3	52.1	15.3	52.1	100	1.77	7.8	11	3.7		
				delta T 50			30.0	102.5	30.0	102.5	100	3.49	15.4	17	5.7		
		8.8	16	delta T 25	18.8	66	14.5	49.4	14.5	49.4	100	1.47	6.5	7	2.3		
				delta T 50			28.7	97.9	28.7	97.9	100	2.92	12.9	12	4.0		
		10.0	18	delta T 25	20.0	68	13.5	46.1	13.5	46.1	100	1.21	5.3	5	1.7		
				delta T 50			27.1	92.6	27.1	92.6	100	2.44	10.7	8	2.7		
		11.1	20	delta T 25	21.1	70	12.6	43.1	12.6	43.1	100	1.02	4.5	4	1.3		
				delta T 50			25.5	87.1	25.5	87.1	100	2.07	9.1	6	2.0		
		34	93	5.5	10	delta T 25	15.5	60	18.5	63.0	18.5	63.0	100	2.98	13.1	30	10.0
						delta T 50			36.1	123.1	36.1	123.1	100	5.83	25.7	48	16.1
6.6	12			delta T 25	16.6	62	17.8	60.8	17.8	60.8	100	2.40	10.6	19	6.4		
				delta T 50			34.8	118.8	34.8	118.8	100	4.69	20.7	31	10.4		
7.7	14			delta T 25	17.7	64	17.1	58.4	17.1	58.4	100	1.98	8.7	13	4.3		
				delta T 50			33.6	114.6	33.6	114.6	100	3.89	17.1	21	7.0		
8.8	16			delta T 25	18.8	66	16.4	55.9	16.4	55.9	100	1.66	7.3	9	3.0		
				delta T 50			32.3	110.2	32.3	110.2	100	3.27	14.4	15	5.0		
10.0	18			delta T 25	20.0	68	15.5	53.0	15.5	53.0	100	1.39	6.1	6	2.0		
				delta T 50			30.8	105.2	30.8	105.2	100	2.75	12.1	11	3.7		
11.1	20			delta T 25	21.1	70	14.6	49.8	14.6	49.8	100	1.18	5.2	5	1.7		
				delta T 50			29.3	99.9	29.3	99.9	100	2.36	10.4	8	2.7		
37	99			5.5	10	delta T 25	15.5	60	21.2	72.2	21.2	72.2	100	3.40	15.0	39	13.0
						delta T 50			41.3	140.9	41.3	140.9	100	6.64	29.3	62	20.7
		6.6	12	delta T 25	16.6	62	20.5	70.0	20.5	70.0	100	2.75	12.1	25	8.4		
				delta T 50			40.0	136.4	40.0	136.4	100	5.37	23.6	40	13.4		
		7.7	14	delta T 25	17.7	64	19.8	67.7	19.8	67.7	100	2.28	10.0	17	5.7		
				delta T 50			38.8	132.4	38.8	132.4	100	4.47	19.7	28	9.4		
		8.8	16	delta T 25	18.8	66	19.1	65.3	19.1	65.3	100	1.93	8.5	12	4.0		
				delta T 50			37.6	128.3	37.6	128.3	100	3.79	16.7	20	6.7		
		10.0	18	delta T 25	20.0	68	18.3	62.6	18.3	62.6	100	1.63	7.2	9	3.0		
				delta T 50			36.2	123.5	36.2	123.5	100	3.22	14.2	15	5.0		
		11.1	20	delta T 25	21.1	70	17.6	60.0	17.6	60.0	100	1.41	6.2	7	2.3		
				delta T 50			34.8	118.9	34.8	118.9	100	2.79	12.3	11	3.7		
		43	109	5.5	10	delta T 25	15.5	60	26.4	90.2	26.4	90.2	100	4.23	18.6	60	20.1
						delta T 50			-	-	-	-	-	-	-	-	-
6.6	12			delta T 25	16.6	62	25.7	87.8	25.7	87.8	100	3.43	15.1	40	13.4		
				delta T 50			50.3	171.5	50.3	171.5	100	6.71	29.5	63	21.1		
7.7	14			delta T 25	17.7	64	25.1	85.7	25.1	85.7	100	2.87	12.6	28	9.4		
				delta T 50			49.0	167.3	49.0	167.3	100	5.61	24.7	44	14.7		
8.8	16			delta T 25	18.8	66	24.5	83.5	24.5	83.5	100	2.45	10.8	20	6.7		
				delta T 50			47.8	163.2	47.8	163.2	100	4.79	21.1	32	10.7		
10.0	18			delta T 25	20.0	68	23.8	81.1	23.8	81.1	100	2.10	9.2	15	5.0		
				delta T 50			46.5	158.8	46.5	158.8	100	4.11	18.1	24	8.0		
11.1	20			delta T 25	21.1	70	23.1	78.8	23.1	78.8	100	1.83	8.1	11	3.7		
				delta T 50			45.3	154.7	45.3	154.7	100	3.61	15.9	18	6.0		

NB: CW Pressure Drop must be ≥ 5 kPa

PERFORMANCE DATA

Entering Water Temperature: 12°C (54°F)

Return Air Temperature		CW Temp Rise		delta T	Leaving Water Temp		Net Total Capacity		Net Sensible Capacity		SHR	CW Flow		CW Pressure Drop Coil + Valve			
°C DB	°F DB	°C	°F	Model	°C	°F	kW	MBH	kW	MBH	%	m³/h	GPM	kPa	Ft H ₂ O		
32	90	5.5	10	delta T 25	17.5	64	14.8	50.6	14.8	50.6	100	2.41	10.6	20	6.7		
				delta T 50			29.0	98.9	29.0	98.9	100	4.72	20.8	31	10.4		
		6.6	12	delta T 25	18.6	66	14.1	48.3	14.1	48.3	100	1.92	8.5	12	4.0		
				delta T 50			27.8	94.7	27.8	94.7	100	3.77	16.6	20	6.7		
		7.7	14	delta T 25	19.7	68	13.4	45.7	13.4	45.7	100	1.56	6.9	8	2.7		
				delta T 50			26.4	90.2	26.4	90.2	100	3.09	13.6	13	4.3		
		8.8	16	delta T 25	20.8	70	12.5	42.7	12.5	42.7	100	1.28	5.6	6	2.0		
				delta T 50			25.0	85.1	25.0	85.1	100	2.56	11.3	9	3.0		
		10.0	18	delta T 25	22.0	72	11.6	39.5	11.6	39.5	100	1.05	4.6	4	1.3		
				delta T 50			23.4	79.7	23.4	79.7	100	2.11	9.3	6	2.0		
		11.1	20	delta T 25	23.1	74	8.8	30.2	8.8	30.2	100	0.73	3.2	2	0.7		
				delta T 50			21.8	74.4	21.8	74.4	100	1.78	7.8	4	1.3		
		34	93	5.5	10	delta T 25	17.5	64	16.7	56.9	16.7	56.9	100	2.70	11.9	24	8.0
						delta T 50			32.5	110.9	32.5	110.9	100	5.27	23.2	39	13.0
6.6	12			delta T 25	18.6	66	16.0	54.5	16.0	54.5	100	2.16	9.5	16	5.4		
				delta T 50			31.3	106.8	31.3	106.8	100	4.23	18.6	25	8.4		
7.7	14			delta T 25	19.7	68	15.3	52.1	15.3	52.1	100	1.77	7.8	11	3.7		
				delta T 50			30.0	102.5	30.0	102.5	100	3.49	15.4	17	5.7		
8.8	16			delta T 25	20.8	70	14.5	49.5	14.5	49.5	100	1.48	6.5	7	2.3		
				delta T 50			28.7	98.0	28.7	98.0	100	2.92	12.9	12	4.0		
10.0	18			delta T 25	22.0	72	13.6	46.3	13.6	46.3	100	1.22	5.4	5	1.7		
				delta T 50			27.2	92.8	27.2	92.8	100	2.44	10.8	8	2.7		
11.1	20			delta T 25	23.1	74	12.7	43.4	12.7	43.4	100	1.03	4.5	4	1.3		
				delta T 50			25.6	87.4	25.6	87.4	100	2.08	9.1	6	2.0		
37	99			5.5	10	delta T 25	17.5	64	19.3	66.0	19.3	66.0	100	3.12	13.7	33	11.0
						delta T 50			37.8	129.0	37.8	129.0	100	6.10	26.8	52	17.4
		6.6	12	delta T 25	18.6	66	18.7	63.8	18.7	63.8	100	2.51	11.1	21	7.0		
				delta T 50			36.5	124.6	36.5	124.6	100	4.92	21.6	24	8.0		
		7.7	14	delta T 25	19.7	68	18.0	61.5	18.0	61.5	100	2.08	9.2	15	5.0		
				delta T 50			35.3	120.4	35.3	120.4	100	4.08	17.9	23	7.7		
		8.8	16	delta T 25	20.8	70	17.3	59.1	17.3	59.1	100	1.75	7.7	10	3.3		
				delta T 50			34.1	116.2	34.1	116.2	100	3.45	15.2	17	5.7		
		10.0	18	delta T 25	22.0	72	16.5	56.3	16.5	56.3	100	1.47	6.5	7	2.3		
				delta T 50			32.6	111.4	32.6	111.4	100	2.91	12.8	12	4.0		
		11.1	20	delta T 25	23.1	74	15.7	53.6	15.7	53.6	100	1.26	5.6	5	1.7		
				delta T 50			31.3	106.7	31.3	106.7	100	2.52	11.1	9	3.0		
		43	109	5.5	10	delta T 25	17.5	64	24.6	84.0	24.6	84.0	100	3.95	17.4	52	17.4
						delta T 50			-	-	-	-	-	-	-	-	-
6.6	12			delta T 25	18.6	66	24.0	81.8	24.0	81.8	100	3.20	14.1	34	11.4		
				delta T 50			46.8	159.8	46.8	159.8	100	6.26	27.6	55	18.4		
7.7	14			delta T 25	19.7	68	23.4	79.7	23.4	79.7	100	2.68	11.8	24	8.0		
				delta T 50			45.6	155.6	45.6	155.6	100	5.23	23.0	38	12.7		
8.8	16			delta T 25	20.8	70	22.7	77.5	22.7	77.5	100	2.28	10.0	17	5.7		
				delta T 50			44.4	151.5	44.4	151.5	100	4.46	19.6	28	9.4		
10.0	18			delta T 25	22.0	72	22.0	75.0	22.0	75.0	100	1.94	8.6	13	4.3		
				delta T 50			43.1	147.1	43.1	147.1	100	3.81	16.8	20	6.7		
11.1	20			delta T 25	23.1	74	21.3	72.7	21.3	72.7	100	1.70	7.5	10	3.3		
				delta T 50			41.9	142.9	41.9	142.9	100	3.34	14.7	16	5.4		

NB: CW Pressure Drop must be ≥ 5 kPa

PERFORMANCE DATA

Entering Water Temperature: 14°C (57°F)

Return Air Temperature		CW Temp Rise		delta T	Leaving Water Temp		Net Total Capacity		Net Sensible Capacity		SHR	CW Flow		CW Pressure Drop Coil + Valve			
°C DB	°F DB	°C	°F	Model	°C	°F	kW	MBH	kW	MBH	%	m³/h	GPM	kPa	Ft H ₂ O		
32	90	5.5	10	delta T 25	19.5	67	13.0	44.3	13.0	44.3	100	2.13	9.4	15	5.0		
				delta T 50			25.4	86.8	25.4	86.8	100	4.16	18.3	24	8.0		
		6.6	12	delta T 25	20.6	69	12.3	41.9	12.3	41.9	100	1.68	7.4	9	3.0		
				delta T 50			24.2	82.4	24.2	82.4	100	3.30	14.5	15	5.0		
		7.7	14	delta T 25	21.7	71	11.4	39.0	11.4	39.0	100	1.35	5.9	6	2.0		
				delta T 50			22.8	77.8	22.8	77.8	100	2.68	11.8	10	3.3		
		8.8	16	delta T 25	22.8	73	10.6	36.2	10.6	36.2	100	1.10	4.8	4	1.3		
				delta T 50			21.3	72.8	21.3	72.8	100	2.20	9.7	7	2.3		
		10.0	18	delta T 25	24.0	75	9.0	30.8	9.0	30.8	100	0.83	3.6	2	0.7		
							delta T 50	19.6	66.9	19.6	66.9	100	1.79	7.9	5	1.7	
				delta T 25			7.0	23.8	7.0	23.8	100	0.59	2.6	1	0.3		
							delta T 50	17.8	60.7	17.8	60.7	100	1.47	6.5	3	1.0	
		34	93	5.5	10	delta T 25	19.5	67	14.8	50.6	14.8	50.6	100	2.41	10.6	20	6.7
						delta T 50			29.0	98.8	29.0	98.8	100	4.72	20.8	31	10.4
6.6	12			delta T 25	20.6	69	14.1	48.3	14.1	48.3	100	1.92	8.5	12	4.0		
				delta T 50			27.7	94.6	27.7	94.6	100	3.77	16.6	20	6.7		
7.7	14			delta T 25	21.7	71	13.4	45.8	13.4	45.8	100	1.57	6.9	8	2.7		
				delta T 50			26.4	90.2	26.4	90.2	100	3.09	13.6	13	4.3		
8.8	16			delta T 25	22.8	73	12.6	43.1	12.6	43.1	100	1.29	5.7	6	2.0		
				delta T 50			25.1	85.6	25.1	85.6	100	2.57	11.3	9	3.0		
10.0	18			delta T 25	24.0	75	11.7	39.8	11.7	39.8	100	1.05	4.6	4	1.3		
							delta T 50	23.4	79.8	23.4	79.8	100	2.11	9.3	6	2.0	
				delta T 25			10.1	34.4	10.1	34.4	100	0.83	3.6	2	0.7		
							delta T 50	21.9	74.8	21.9	74.8	100	1.79	7.9	5	1.7	
37	99			5.5	10	delta T 25	19.5	67	17.5	59.8	17.5	59.8	100	2.83	12.5	27	9.0
						delta T 50			34.2	116.8	34.2	116.8	100	5.54	24.4	43	14.4
		6.6	12	delta T 25	20.6	69	16.9	57.6	16.9	57.6	100	2.28	10.0	17	5.7		
				delta T 50			33.0	112.6	33.0	112.6	100	4.45	19.6	28	9.4		
		7.7	14	delta T 25	21.7	71	16.2	55.3	16.2	55.3	100	1.88	8.3	12	4.0		
				delta T 50			31.8	108.4	31.8	108.4	100	3.68	16.2	18	6.0		
		8.8	16	delta T 25	22.8	73	15.5	52.9	15.5	52.9	100	1.57	6.9	8	2.7		
				delta T 50			30.5	104.1	30.5	104.1	100	3.10	13.6	14	4.7		
		10.0	18	delta T 25	24.0	75	14.6	49.8	14.6	49.8	100	1.31	5.8	6	2.0		
							delta T 50	29.1	99.2	29.1	99.2	100	2.60	11.5	10	3.3	
				delta T 25			13.6	46.3	13.6	46.3	100	1.10	4.8	4	1.3		
							delta T 50	27.7	94.4	27.7	94.4	100	2.24	9.8	7	2.3	
		43	109	5.5	10	delta T 25	19.5	67	22.9	78.0	22.9	78.0	100	3.67	16.2	45	15.1
						delta T 50			44.4	151.6	44.4	151.6	100	7.13	31.4	72	24.1
6.6	12			delta T 25	20.6	69	22.2	75.8	22.2	75.8	100	2.97	13.1	30	10.0		
				delta T 50			43.4	148.0	43.4	148.0	100	5.81	25.6	47	15.7		
7.7	14			delta T 25	21.7	71	21.6	73.7	21.6	73.7	100	2.48	10.9	21	7.0		
				delta T 50			42.1	143.7	42.1	143.7	100	4.84	21.3	33	11.0		
8.8	16			delta T 25	22.8	73	20.9	71.4	20.9	71.4	100	2.10	9.3	15	5.0		
				delta T 50			40.9	139.7	40.9	139.7	100	4.12	18.1	24	8.0		
10.0	18			delta T 25	24.0	75	20.2	68.9	20.2	68.9	100	1.79	7.9	11	3.7		
							delta T 50	39.6	135.2	39.6	135.2	100	3.51	15.5	17	5.7	
				delta T 25			19.3	65.9	19.3	65.9	100	1.54	6.8	8	2.7		
							delta T 50	38.4	131.0	38.4	131.0	100	3.07	13.5	13	4.3	

NB: CW Pressure Drop must be ≥ 5 kPa

PERFORMANCE DATA

Entering Water Temperature: 16°C (61°F)

Return Air Temperature		CW Temp Rise		delta T	Leaving Water Temp		Net Total Capacity		Net Sensible Capacity		SHR	CW Flow		CW Pressure Drop Coil + Valve	
°C DB	°F DB	°C	°F	Model	°C	°F	kW	MBH	kW	MBH	%	m³/h	GPM	kPa	Ft H ₂ O
32	90	5.5	10	delta T 25	21.5	71	11.1	38.0	11.1	38.0	100	1.83	8.1	11	3.7
				delta T 50			21.8	74.5	21.8	74.5	100	3.60	15.9	18	6.0
		6.6	12	delta T 25	22.6	73	10.3	35.3	10.3	35.3	100	1.43	6.3	7	2.3
				delta T 50			20.5	70.0	20.5	70.0	100	2.83	12.5	11	3.7
		7.7	14	delta T 25	23.7	75	9.6	32.7	9.6	32.7	100	1.14	5.0	4	1.3
				delta T 50			19.0	64.9	19.0	64.9	100	2.26	9.9	7	2.3
		8.8	16	delta T 25	24.8	77	8.6	29.4	8.6	29.4	100	0.90	4.0	3	1.0
				delta T 50			17.5	59.8	17.5	59.8	100	1.83	8.1	5	1.7
		10.0	18	delta T 25	26.0	79	6.1	20.7	6.1	20.7	100	0.57	2.5	1	0.3
				delta T 50			15.6	53.3	15.6	53.3	100	1.45	6.4	3	1.0
		11.1	20	delta T 25	27.1	81	3.2	10.9	3.2	10.9	100	0.29	1.3	1	0.3
				delta T 50			10.7	36.6	10.7	36.6	100	0.93	4.1	1	0.3
34	93	5.5	10	delta T 25	21.5	71	13.0	44.3	13.0	44.3	100	2.12	9.4	15	5.0
				delta T 50			25.4	86.6	25.4	86.6	100	4.16	18.3	24	8.0
		6.6	12	delta T 25	22.6	73	12.3	41.9	12.3	41.9	100	1.68	7.4	9	3.0
				delta T 50			24.1	82.4	24.1	82.4	100	3.30	14.5	15	5.0
		7.7	14	delta T 25	23.7	75	11.5	39.3	11.5	39.3	100	1.35	6.0	6	2.0
				delta T 50			22.8	77.9	22.8	77.9	100	2.68	11.8	10	3.3
		8.8	16	delta T 25	24.8	77	10.7	36.5	10.7	36.5	100	1.10	4.9	4	1.3
				delta T 50			21.4	72.9	21.4	72.9	100	2.20	9.7	7	2.3
		10.0	18	delta T 25	26.0	79	9.7	33.0	9.7	33.0	100	0.88	3.9	3	1.0
				delta T 50			19.7	67.3	19.7	67.3	100	1.80	7.9	5	1.7
		11.1	20	delta T 25	27.1	81	7.0	23.8	7.0	23.8	100	0.59	2.6	1	0.3
				delta T 50			18.0	61.4	18.0	61.4	100	1.49	6.5	3	1.0
37	99	5.5	10	delta T 25	21.5	71	15.7	53.6	15.7	53.6	100	2.55	11.2	22	7.4
				delta T 50			30.7	104.8	30.7	104.8	100	4.99	22.0	35	11.7
		6.6	12	delta T 25	22.6	73	15.1	51.4	15.1	51.4	100	2.04	9.0	14	4.7
				delta T 50			29.4	100.5	29.4	100.5	100	3.99	17.6	22	7.4
		7.7	14	delta T 25	23.7	75	14.4	49.0	14.4	49.0	100	1.67	7.4	9	3.0
				delta T 50			28.2	96.3	28.2	96.3	100	3.29	14.5	15	5.0
		8.8	16	delta T 25	24.8	77	13.6	46.5	13.6	46.5	100	1.39	6.1	6	2.0
				delta T 50			26.8	91.5	26.8	91.5	100	2.74	12.0	11	3.7
		10.0	18	delta T 25	26.0	79	12.7	43.4	12.7	43.4	100	1.15	5.0	4	1.3
				delta T 50			25.4	86.7	25.4	86.7	100	2.29	10.1	7	2.3
		11.1	20	delta T 25	27.1	81	11.9	40.5	11.9	40.5	100	0.97	4.3	3	1.0
				delta T 50			23.9	81.5	23.9	81.5	100	1.94	8.6	5	1.7
43	109	5.5	10	delta T 25	21.5	71	21.1	71.8	21.1	71.8	100	3.39	14.9	38	12.7
				delta T 50			41.0	139.8	41.0	139.8	100	6.59	29.0	61	20.4
		6.6	12	delta T 25	22.6	73	20.4	69.6	20.4	69.6	100	2.74	12.1	25	8.4
				delta T 50			39.9	136.1	39.9	136.1	100	5.35	23.6	40	13.4
		7.7	14	delta T 25	23.7	75	19.8	67.5	19.8	67.5	100	2.28	10.0	28	9.4
				delta T 50			38.6	131.8	38.6	131.8	100	4.45	19.6	28	9.4
		8.8	16	delta T 25	24.8	77	19.1	65.3	19.1	65.3	100	1.93	8.5	12	4.0
				delta T 50			37.5	127.8	37.5	127.8	100	3.78	16.6	20	6.7
		10.0	18	delta T 25	26.0	79	18.4	62.8	18.4	62.8	100	1.63	7.2	9	3.0
				delta T 50			36.1	123.3	36.1	123.3	100	3.21	14.1	14	4.7
		11.1	20	delta T 25	27.1	81	17.7	60.3	17.7	60.3	100	1.42	6.2	7	2.3
				delta T 50			34.9	119.1	34.9	119.1	100	2.80	12.3	11	3.7

NB: CW Pressure Drop must be ≥ 5 kPa

UNIT TECHNICAL SPECIFICATION

Model		delta T25	delta T50
Fans			
Quantity	No.	2	4
Nominal Air Flow	m3/h (cfm)	4300 (2530)	8550 (5032)
Sound Level	dB(A)*	67	70
Max Air Flow - Fully Recessed	m3/h (cfm)	5390 (3170)	10910 (6420)
Max Air Flow - Semi Recessed	m3/h (cfm)	5990 (3525)	12240 (7200)
Electrical Characteristics	V/Ph/Hz	230/1/50-60	
Max Fan Motor Current (each) - Fully Recessed	A	3.1	
Max Fan Motor Power (each) - Fully Recessed	W	505	
Absorbed Power (Fully Recessed) - 50Hz	kW	0.700	1.360
Absorbed Power (Semi Recessed) - 50Hz	kW	0.560	0.930
Electrical Characteristics	V/Ph/Hz	115/1/60	
Max Fan Motor Current (each) - Fully Recessed	A	4.2	
Max Fan Motor Power (each) - Fully Recessed	W	350	
Absorbed Power (Fully Recessed) - 60Hz	kW	0.680	1.320
Absorbed Power (Semi Recessed) - 60Hz	kW	0.540	0.900
Chilled Water Coil			
Rows	No.	3	3
Face Area	m2 (ft2)	0.49 (5.27)	0.91 (9.80)
Tubes/Fins		Cu tubes / Al fins	
Water Connections			
Chilled Water Supply and Return - 60Hz units	NPT	1"	1 1/2"
Chilled Water Supply and Return - 50Hz units	BSPT	1"	1 1/2"
Condensate Pump	mm	6	6
Filter			
Type		G2	
Quantity	No.	2	2
Weight and Dimensions			
Unit Packed Shipping Weight	kg	105	185
Unit Weight	kg	90	170
Unit Weight Filled With Water	kg	95	178
Unit Dimensions (HxWxD)	mm	890 x 450 x 895	1734 x 450 x 895
	inches	35 x 18 x 35	68 x 18 x 35
Unit Packed Dimensions	mm	1000 x 470 x 1040	1845 x 470 x 1040
	inches	39 x 19 x 41	73 x 19 x 41
Electrical Drawer Weight	kg	19	19
Electrical Drawer Packed Shipping Weight	kg	20	20
Electrical Drawer Dimensions (HxWxD)	mm	88 x 482 x 955	88 x 482 x 955
	inches	3 1/2 x 19 x 37 1/2	3 1/2 x 19 x 37 1/2

60Hz UNITS

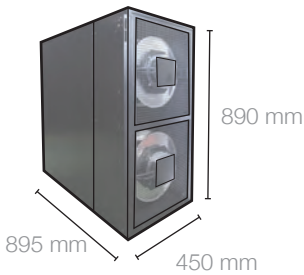

* Free Field 2m from front of unit

Capacity Correction Factors

	Glycol Type	Percent Glycol by Weight					
		0%	10%	20%	30%	40%	50%
Correction Factor for Cooling Capacity	Ethylene	1.00	0.97	0.93	0.88	0.81	0.75
	Propylene	1.00	0.96	0.90	0.82	0.77	0.74
Correction Factor for Pressure Drop	Ethylene	1.00	1.04	1.13	1.21	1.31	1.41
	Propylene	1.00	1.09	1.20	1.35	1.52	1.67

Technical Specification

CABINET is designed to slide into any standard EIA 310D IT rack in either a fully or semi-recessed configuration. Cabinet construction is extruded aluminum frame and galvanized steel panels externally covered with PVC film and internally insulated with thermo-acoustic open-cell expanded polyurethane, 10mm thickness, self-extinguishing class 1, 60 kg/m³ and a thermal conductivity of 0.036 W/mK. Panels are sealed with air-tight gaskets of dual density polyurethane.

COOLING COIL chilled water type with copper tubes mechanically expanded into aluminum fins; rust proof frame. Easy access air bleed valve on header.

TWO WAY or THREE WAY chilled water valve located in return air stream complete with modulating electric actuator.

WATER PIPING copper tubes with vapor-proof thermal insulation.

QUICK CONNECT COUPLINGS tool-less quick connect fittings on supply and return pipes for fast connection to chilled water supply and return pipes.

CONDENSATE PUMP located in drain pan.

CONDENSATE DRIP TRAY stainless steel under entire coil assembly.

AIR FILTER G4 synthetic fiber filters with aluminum frame.

DIFFERENTIAL PRESSURE SWITCH for clogged filter alarm.

SUPPLY AIR FANS single inlet, backward curved blades statically and dynamically balanced, directly coupled brushless electronically commutated (EC) motor with 75,000 hours L₁₀ life.

PROTECTIVE ENCLOSURE on fan discharge.

DIFFERENTIAL PRESSURE TRANSMITTER for air flow measurement and fan alarms.

QUICK ELECTRICAL CONNECTION fast on type to connect the unit to power source, to the control panel and the temperature probe.

TEMPERATURE PROBES on room air, supply air, return air and inlet water.

CONTROL PANEL microprocessor and electrical controls are mounted in easy access 2U drawer enclosure of epoxy powder painted galvanised steel suitable for local or remote mounting in any EIA 310 cabinet.

- Main interlocking power switch
- Automatic fuse protection for each component
- Fan motor contactors
- Transformer for auxiliary services
- Components and wiring in compliance with applicable IEC norm
- Microprocessor control

MICROPROCESSOR CONTROL for single or dual unit for management, monitoring and control:

- Supply air temperature sensor
- Server air inlet temperature sensor
- Modulating chilled water valve
- Variable fan speed control
- Supply air temperature limit
- Control keyboard with two levels of password access
- Alarm reset
- Unit off switch
- Watchdog function
- Management of all alarm conditions:
 - High air temperature
 - Low air temperature
 - High water temperature
 - Low water temperature
 - Fan failure
 - Loss of air flow
 - Loss of water flow
 - Change filter
 - Common alarm
- Password
- RS485 serial board for BMS connection
- Web card with SNMP

USER INTERFACE 4-line backlit display of conditions, status and operating parameters:

- Display of room air temperature
- Display of supply air temperature
- Display of set point air temperature
- Display of operating parameters

STATUTORY INFORMATION

Legal Disclaimer

Although every effort has been made to ensure the accuracy of this manual, Datacentience does not warrant the information presented here to be authoritative, error free or complete. This manual is not a substitute for a detailed installation-specific plan. Datacentience accepts no liability for damages, violations of codes, improper installation, system failures or any other problems based on the use of this manual.

The information here is provided as is and has been provided solely for the evaluation of a Datacentience product specification and installation.

In no event shall Datacentience be liable for any direct, indirect, consequential, punitive, special, or incidental damages (including, without limitation, damages for loss of business, contract, revenue, data, information, or business interruption) resulting from, arising out, or in connection with the use of, or inability to use this publication or the content, even if Datacentience has been expressly advised of the possibility of such damages. Datacentience reserves the right to make changes to the content of the publication any time without notice.

Copyright, intellectual, and all other proprietary rights in the content (including but not limited to software, audio, video, text, and photographs) rests with Datacentience or its licensors.

All rights in the content not expressly granted herein are reserved. No rights of any kind are licensed or assigned or shall otherwise pass to persons accessing this information.

This publication shall not be for resale in whole or in part.

Compliance Approval

- CE
-  approved components

This manual is available for download from our website
www.datacentience.com



Datacentience
26/27 Great Sutton Street
London EC1V 0DS
United Kingdom

T +44 (0)20 7250 5787
F +44 (0)20 7250 5790

www.datacentience.com